



◀ HENAI -Laser Safety World
SINCE 2012

- Applications in top 500 companies and top scientific research institutes
 - Highly recommended by professionals in laser field
- Third-party authority certification



Personal Protection
Area Protection
Active Protection

Laser Safety Product Catalog



Official
Accounts



Mini
Programs



HENAI Trade (Shanghai) Co., Ltd
Anhui HENAI Industrial Automation Co., Ltd

Email: seles@henai-sh.com

Website: <http://www.lasersafetyworld.com>

Please scan the QR code for more information about laser safety solutions.

CONTENT

about us HENAI, SINCE 2012

Owner of the brand of Laser Safety World[®], HENAI was founded in 2012. At the beginning of foundation, the company was a supplier to provide laser welding protection and fume extraction system, in the field of auto industry and new energy. During more than 10 years, the company has 2 main groups of business: Environmental fume&dust extraction (Brand HENAI[®]) and laser safety solutions (Brand Laser Safety World[®]).

There are 2 wholly owned subsidiaries: HENAI Trade (Shanghai) Co., Ltd and Anhui HENAI Industrial Automation Co., Ltd. HENAI Shanghai is the marketing center, as well as the agent of German JUTEC, and the agent of UK Lasermet. Meanwhile, A base of R&D and production covers an area of 1500m² of its own property rights in Anhui province.and it has passed the 3 certification systems of ISO9001: 2015、ISO14001:2015、ISO45001:2018.

All of the laser safety products manufactured by HENAI are tested by a third party, such as Test Center of Chinese Academy of Sciences, Quality Supervision and Inspection Center for Special Safety Protection Products, and TÜV Rheinland, according to the international laser safety standards: GB7247, EN60825/EN207/EN12254. Part of products, such as the laser safety curtain Laser Defender[®], the laser safety barrier Laser Knight[®] and laser safety enclosure Laser Cage[®], becomes the domestically pioneer, and has got a good reputation from its user.

Based on getting in touch with National Standardization Committee and well knowing of laser safety documents, the company' s engineer keeps on launching new products every year to meet the specified needs of different customers. These products are widely used in the area of laser manufacturing, automobile&new energy, semiconductorµelectronics, optical communication, aerospace, scientific research&universities and medical facilities.

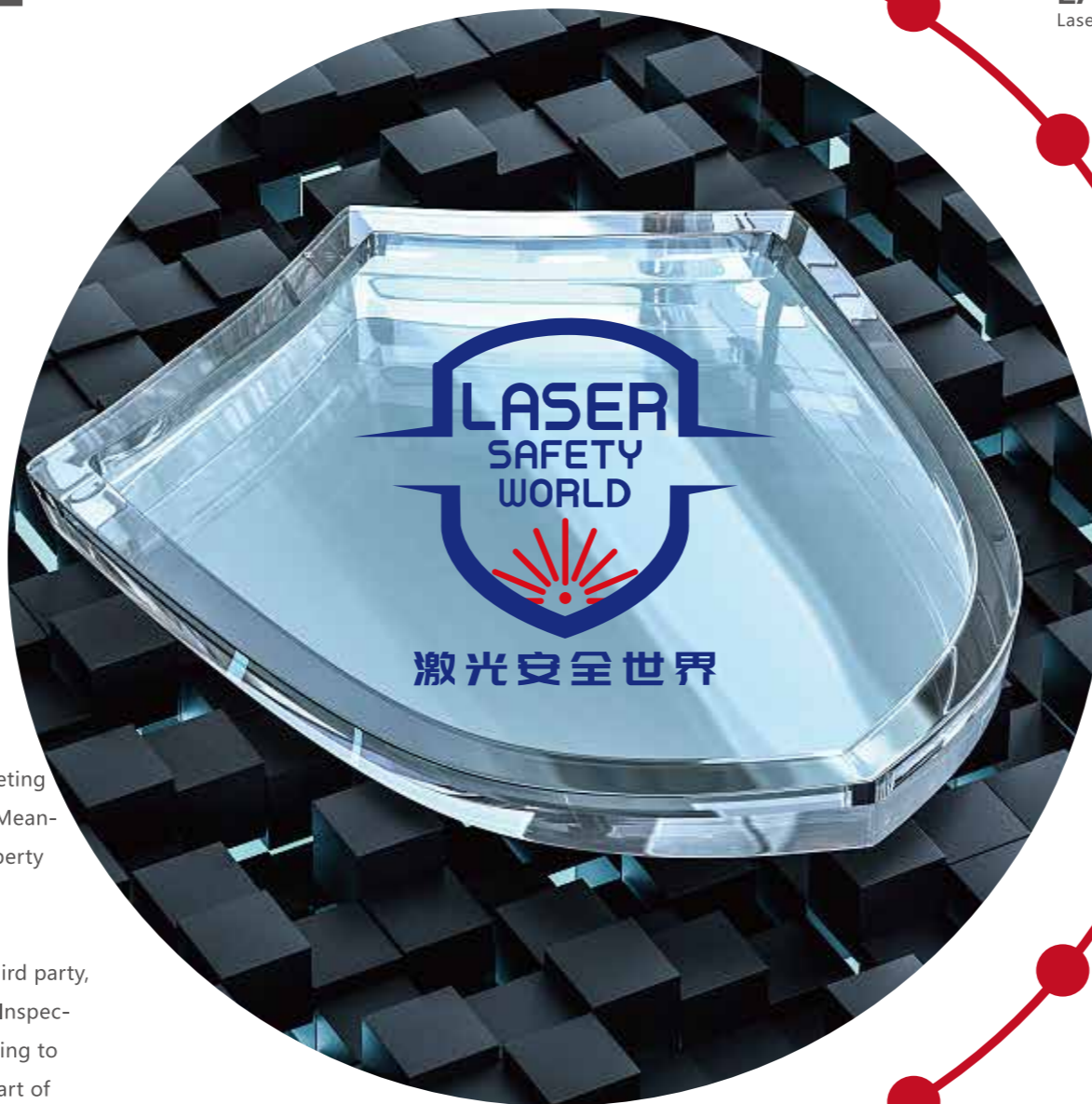

COMPANY PROFILE _____ 01
Overview, Qualifications, Customers

LASER SAFETY KNOWLEDGE _____ 05
Laser Hazard, Safety Standards, Terminology

Laser Safety World[®] _____ 07
Laser Safety Eyewear

Laser Safety World[®] _____ 12
Laser Safety Face Shield

Laser Safety World[®] _____ 15
Laser Protection Clothing&Gloves

Laser Safety World[®] _____ 16
Laser Safety Windows

Laser Defender[®] _____ 19
Laser Safety Curtains

Laser Knight[®] _____ 23
Laser Safety Barriers

Laser Hero[®] _____ 27
Optical Table Laser Guarding System

Laser Cage[®] _____ 30
Laser Safety Enclosure

Laser Castle[®] _____ 32
Laser Safety Cabins

Laser Interlock _____ 34
Laser Safety Interlock System

Active Laser Guarding System _____ 34

Disclaimers _____ 35

Certificate of Honor



Laser Hazards

The influences of laser radiation to human include thermal hazards, photochemical hazards and nonlinear effects. It's complicated, usually result from one or several factors, which is dependent on wavelength of the laser, pulse width, focus size, irradiance and the time duration.

The damages of laser radiation to eyes will cause the photokeratitis, corneal coagulation, carbonization and perforation, lens cloudiness, visual dysfunction "flash blindness" and retinal coagulation, bleeding, and rupture. When the visible light with high intensity or near-infrared light enters the eye, it can pass through the human eye refractive medium and focus light onto the retina. At this time, the laser energy density on the retina reaches to thousands or even tens of thousands of times, and a large amount of light energy is instantly focused on the retina, causing the temperature of the photo-receptor cell layer of the retina to rise rapidly, resulting in photoreceptor cell coagulation degeneration necrosis and loss of photosensitive function.

There also are two kinds of damage to human skins caused by laser radiation: the photochemical hazards and thermal hazards. Different wavelengths of beam will pass through the epidermis, dermis, and results in an immediate hazard and chronic hazard.

The immediate hazard: the visible light and laser in the infrared spectrum hitting on skin will cause biological effects including the erythema and blister. When the tissue with strong surface absorption is hit by a very short pulse or a high power laser, generally there will be a offwhite carbonization.

The chronic hazard: repeated or chronic laser exposure, such as optical radiation in the ultraviolet region of the spectrum can lead to long-term laser hazard effects (i.e accelerating skin aging and skin cancer).

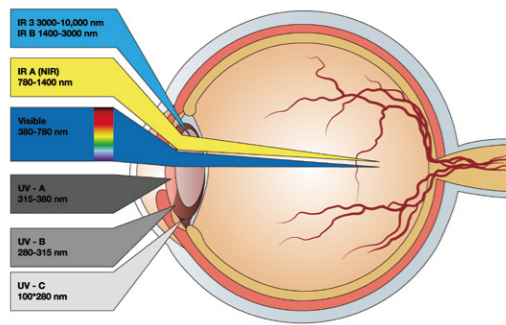

CIE	Spectrum	Hazards	Eye	Skins
UV Radiation C	(180nm~280nm)	P H a z a r d s T h e r m a l H a z a r d s	Photokeratitis	Erythema (sunburn) Accentuate Skin Ageing, Pigmentation
UV Radiation B	(280nm~315nm)			
UV Radiation A	(315m~400nm)			
Visible Light	(400nm~780nm)	Photochemical Cataract	Pigmentation, Photosensitization, Skin Burns	
Infrared Radiation A	(780nm~1400nm)	C a t a r a c t R e t i n a l B u r n s	Cataract, Retinal Burns	Skin Burns
Infrared Radiation B	(1.4μm~3.0μm)			
Infrared Radiation C	(3.0μm~1mm)			

Laser Safety Terms



* AEL ACCESSIBLE EMISSION LIMIT

The maximum accessible emission level permitted within a particular class.

* MPE MAXIMUM PERMISSIBLE EXPOSURE

It is the maximum level of laser radiation the human eye or skin can be exposed to without hazardous effects or biological changes. MPE is dependent on wavelength of the laser, the time duration and the energy involved.

* PEL PROTECTIVE EXPOSURE LIMIT

In condition of the laser irradiation exposed on surface does not exceed class 1 of AEL, the maximum level of laser radiation the human eye or skin can be exposed.

* NOHA NOMINAL OCULAR HAZARD AERA

The zone that beam irradiance exceeds MPE of the cornea

* NOHD NOMINAL OCULAR HAZARD DISTANCE

The distance that beam irradiance equals MPE of the cornea

* VISIBLE LIGHT TRANSMITTANCE (VLT)

IT SHOULD BE USED IN GOOD LIGHTING ENVIRONMENT
IF VLT VALUE LESS THAN 20%

Laser Safety Standards, Classification and Protection Measures

In Laser Safety, there are several primary standards (or norms) that are followed, Chinese Standards (GB7247.1-2012, GB/T7247.14-2012, GJB1762-1993, GB/T18151-2008, GBZ2.2-2007), IEC Standards (IEC60825), European Standards (EN60825, EN207, EN208) and ANSI (ANSI -Z136.1, ANSI -Z136.7). Lasers are categorized into different classes according to their ability to cause eye and other damage. A description of each class of laser is given below: (Remarks: please refer to the standards while in practical use.)

Item	Class						
	1	1M	2	2M	3R	3B	4
Hazards	Safe under all conditions of normal use	Safe except when used with optical instruments for intrabeam viewing	The blink reflex will limit the exposure in the eye	Safe except when used with optical instruments for intrabeam viewing	Eye injuries may occur if you directly view the beam.	Eye injuries may occur if you directly view the beam.	High power, diffuse reflection
Enclosure	Needed						
Interlock	Designed to prevent the barrier panel moving, except AEL less than 3R				Designed to prevent the barrier panel moving, except AEL less than 3B or 3R		
Remote Control	No need				Needed		
Manual Reset	No need						Remote interlockstart
Key control	No need					Laser device out of use when removing the key	
Alarm Device of Radiation	No need				Issue warning signs and alerts when laser power on or charge a battery; only applied to invisible radiation for class 3R laser		
Classification Sign	Mark with words			Standard warning signs			



Laser Safety Terms

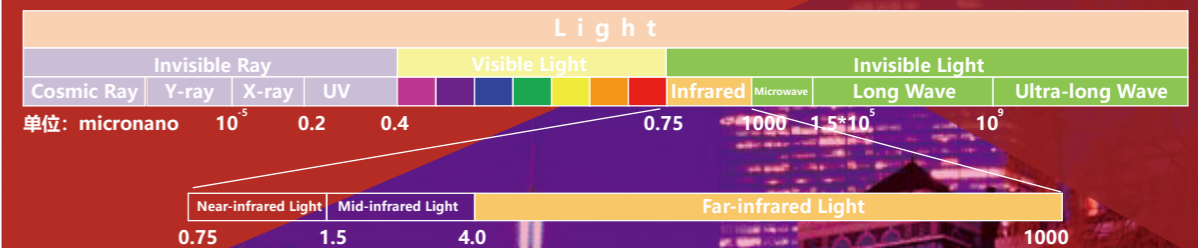

* OPERATION MODE

Laser Mode	Symbol	Pulse Width
Continuous	D	> 0.25 s
Pulse	I	> 1μs - 0.25s
Giant Pulse	R	1ns - 1μs
Modelocked	M	< 1ns

* COMPARISON OF OD AND LIGHT TRANSMITTANCE

OD	Transmission of light	Attenuation Factor	OD	Transmission of light	Attenuation Factor
0	1	1	5	0.00001	100000
1	0.1	10	6	0.000001	1000000
2	0.01	100	7	0.0000001	10000000
3	0.001	1000	8	0.00000001	100000000
4	0.0001	10000	9	0.000000001	1000000000

Laser Safety Eyewear- Laser Safety World[®]

Laser Safety World[®] eyewear are manufactured with material of polycarbonate (except for p/n CDE and p/n ADEF-D5T90 made of glasses material), compliant with European laser safety standards EN207, and are provided with high level of protection from laser radiation. High optical density(OD) and visible light transmittance(VLT) for its lens, the glasses have no optical distortion and are not easy to scratch. *Laser Safety World[®]* eyewear are widely applied to many areas: laser manufacture, scientific research, laser alignment system, medical and cosmetic facilities.

Standards and Test:

Laser Safety World[®] eyewear are tested based on standards EN207&EN167, and are compliant with CMA and ilac-MRA, accreditation system which have been integrated to international mutual recognition. It means the *Laser Safety World[®]* eyewear are also compliant with CE standards, and meet the threshold of European market.

Frame Style: You can choose from the follow up three styles



Frame Style:

*Classic Style: regular standard style, large surrounding, eyeglass arms adjustable, available to wear prescription glasses, suitable for most persons and applications.





*Clip-on Style: clamped and fixed on the prescription glasses, available to be flipped up, but increase the weight of frames causing a possibility of falling.





*Strap-up Style: fully surrounded and protected, no worries about eyewear falling, but not comfortable to wear prescription glasses together.

Selections: please read the following table.

OD (optical density) is the amount of light attenuated by the lens of different particular wavelength that is being measured, e.g.OD4 means a light transmittance of 1/10000, and so on. For more details of OD value of each particular wavelength, please refer to the test report.VLT(visible light transmittance) is the amount of visible light(400-700nm) that can pass through the lens of a pair of glasses. More informally, it means the clearness of the lens of glasses, the higher the VLT value, the clearer the glasses.

P/N	Application	OD	VLT	Photo
A-D4T50	UV, Blue laser	OD6+@190-378nm OD6+@379-463nm	50%	
AB-D5T35	UV, Blue laser, Green laser, Wavelength 532nm.	OD7+@190-350nm OD6+@350-380nm OD5+@380-390nm OD4+@390-410nm OD5+@410-460nm OD6+@460-525nm OD5+@525-538nm OD4+@538-542nm	35%	
AY-D5T15	Yellow	OD3+@560-574nm OD4+@574-575nm OD5+@575-596nm OD3+@596-600nm	15%	
AC-D5T35	UV, Red laser, Wavelength 630nm, 660nm	OD6+@190-280nm OD5+@280-383nm OD4+@383-400nm OD3+@600-630nm OD4+@630-720nm	35%	
ACD-D5T70	Red laser, Wavelength 755nm, 808nm, 810nm	OD6+@190-380nm OD4+@380-383nm OD3+@384-390nm OD3+@740-749nm OD5+@750-760nm OD6+@760-770nm OD7+@770-799nm OD5+@800-855nm OD4+@855-865nm OD6+@808nm	70%	
AD-D5T60	Fiber, IR, wavelength 1064nm, and low light environments	OD7+@190-280nm OD6+@280-335nm OD5+@335-360nm OD6+@360-390nm OD7+@390-440nm OD6+@440-446nm OD5+@446-450nm OD5+@800-809nm OD6+@809-940nm OD7+@940-1100nm	60%	

P/N	Application	OD	VLT	Photo
ADE-D4T35	Fiber IR, Wavelength 1064nm, laser welding/cutting /cleaning	OD7+@190-400nm OD6+@400-410nm OD5+@410-425nm OD4+@425-450nm OD4+@900-930nm OD5+@930-960nm OD6+@960-990nm OD7+@990-1165nm OD6+@1165-1185nm OD5+@1185-1200nm OD4+@1200-1220nm OD3+@1225-1240nm	35%	
ABD-D5T35	Fiber IR, laser welding/cutting /cleaning, and wavelength 532nm &1064nm.	OD7+@190-280nm OD6+@280-535nm OD5+@535-540nm OD4+@540-546nm OD3+@800-850nm OD4+@850-900nm OD5+@900-940nm OD6+@940-962nm OD7+@962-1050nm OD6+@1050-1060nm OD5+@1060-1075nm OD4+@1075-1090nm OD3+@1090-1100nm	35%	
ABD-D8T10	Better version of ABD-D5T35	OD7+@190-510nm OD6+@510-535nm OD5+@535-540nm OD3+@540-546nm OD5+@800-840nm OD6+@840-1019nm OD7+@1019-1100nm OD9+@1064nm	10%	
CD-D6T25	Visible light, Near IR	OD2+@600-625nm OD3+@625-635nm OD4+@635-641nm OD5+@641-645nm OD6+@645-649nm OD7+@649-710nm OD4+@710-760nm OD5+@760-773nm OD6+@773-800nm OD5+@800-900nm OD6+@900-1050nm OD7+@1050-1100nm	25%	

P/N	Application	OD	VLT	Photo
ADEF-D5T40	Fiber IR, Wavelength 1064nm、 1319nm、 1540nm	OD7+@190-280nm OD6+@280-450nm OD5+@450-460nm OD4+@460-475nm OD3+@475-485nm OD3+@780-820nm OD4+@820-850nm OD5+@850-870nm OD6+@870-950nm OD7+@950-1115nm OD6+@1115-1180nm OD5+@1180-1710nm OD4+@1710-1780nm OD3+@1780-1830nm OD2+@1830-1900nm	40%	
CDE	Laser devices with red laser pointer.	OD2+@640-660nm OD3+@660-680nm OD4+@680-725nm OD6+@725-1280nm OD5+@1280-1330nm OD4+@1330-1400nm	60%	
ADEF-D5T90	Medical, Optical communication, Wavelength 1319nm、 1550nm、 2100nm、 2780nm、 2940nm	OD6+@190-265nm OD5+@265-280nm OD3+@880-910nm OD4+@910-990nm OD5+@990-1080nm OD6+@1080-1480nm OD5+@1480-1630nm OD4+@1630-2400nm OD3+@2400-2660nm OD2+@2660-2830nm OD3+@2830-3000nm	90%	
BGR	UV, Blue laser, Red laser, Green laser, Laser pointer, Wavelength 445、450、 473、515、 520、532、 635、660	OD3+@190-400nm OD4+@400-445nm OD5+@445-534nm OD3+@660-700nm	25%	

P/N	App lication	OD	VLT	Photo
CO2-D5T50	CO2 laser	OD6+@10600nm	50%	
CO2-D5T90	CO2 laser	OD6+@10600nm	90%	
IPL	Intense pulsed laser	OD4+@190~2000nm	30%	

More new products, stay tuned!

Laser Safety Face Shield- Laser Safety World[®]

Laser Safety World[®] face shields are designed for providing protection to the face and eyes for jobs that require more protection coverage than laser eyewear offer, e. g a hand-held laser welding machine. This face shield features a ratchet adjustable nape strap for a custom fit. Constructed from durable nylon and a viewing window compliant with laser safety standards EN207. Pivoting action allows users to lift face shield while wearing. There are three styles of laser safety face shield: regular, upgraded version(Model n.Hxxx) and transparent viewing window for full face(Model n.Wxxx), please specify when ordering.

Regular: Superior viewing and observation with filter dimension of 110 x 90. Double shielding can be achieved with laser safety window outer, and completely transparent glass inner. Available clearly viewing with a flip window opened up separately, do not have to lift the whole shield. Comes with snap spring fixation, easily and quickly to replace. Three-position adjustment, suitable for all types of heads.



Upgraded : The upgraded face shield is retrofitted an aluminum housing to protect the entire head, including forehead, chin and ears. It is suitable for applications of kilowatt level power to block the stray light of high power.



Full Face: The face shield with fully transparent viewing window can also be customized, with its broadest view, it is usually applied in a lab.



Selections: please read the following table.

Laser Safety World® face shields are tested based on standards EN207&EN167 and are compliant with CMA and ilac-MRA, accreditation system which have been integrated to international mutual recognition. It means the *Laser Safety World*® face shields are also compliant with CE standards, and meet the threshold of European market. Upgraded version(Model n.Hxxx) and Full Face(Model n.Wxxx)

P/N	Application	OD	VLT	Photo
FS-AB-D5T35	UV, Blue laser, Green laser, Wavelength 532nm.	OD7+@190-350nm OD6+@350-380nm OD5+@380-390nm OD4+@390-410nm OD5+@410-460nm OD6+@460-525nm OD5+@525-538nm OD4+@538-542nm	35%	
FS-AD-D5T60	Fiber, IR, Wavelength 1064nm, and low light environments	OD7+@190-280nm OD6+@280-335nm OD5+@335-360nm OD6+@360-390nm OD7+@390-440nm OD6+@440-446nm OD5+@446-450nm OD5+@800-809nm OD6+@809-940nm OD7+@940-1100nm	60%	
FS-ABD-D5T35	Fiber IR, laser welding/cutting/cleaning, and wavelength 532nm & 1064nm.	OD7+@190-280nm OD6+@280-535nm OD5+@535-540nm OD4+@540-546nm OD3+@800-850nm OD4+@850-900nm OD5+@900-940nm OD6+@940-962nm OD7+@962-1050nm OD6+@1050-1060nm OD5+@1060-1075nm OD4+@1075-1090nm OD3+@1090-1100nm	35%	

P/N	Application	OD	VLT	Photo
FS-ADEF-D5T40	Fiber IR, Wavelength 1064nm、 1319nm、 1540nm	OD7+@190-280nm OD6+@280-450nm OD5+@450-460nm OD4+@460-475nm OD3+@475-485nm OD3+@780-820nm OD4+@820-850nm OD5+@850-870nm OD6+@870-950nm OD7+@950-1115nm OD6+@1115-1180nm OD5+@1180-1710nm OD4+@1710-1780nm OD3+@1780-1830nm OD2+@1830-1900nm	40%	
FS-ADE-D4T35	Fiber IR, Wavelength 1064nm, laser welding/cutti ng/cleaning	OD7+@190-400nm OD6+@400-410nm OD5+@410-425nm OD4+@425-450nm OD4+@900-930nm OD5+@930-960nm OD6+@960-990nm OD7+@990-1165nm OD6+@1165-1185nm OD5+@1185-1200nm OD4+@1200-1220nm OD3+@1225-1240nm	35%	
FS-CO2-D5T50	CO2 laser	OD6+@10600nm	50%	

More new products, stay tuned!

Laser Safety Clothing - Laser Safety World[®]

Cut and sewed of *Laser Defender*[®] curtain fabric, our *Laser Safety World*[®] clothing is the only professional laser protective clothing with independent intellectual property in China. With length of 1.2m, smock style, uniform size, the standard version of protective clothing is designed with adjustable buckle, fitting most body types. We have two kinds of protective clothing, respectively applicable to photonics and industry field. The photonics version with outer lining characterized with dust-free, anti-static and flame retardant is suitable for low power, clean room, optical communication, semiconductor and microelectronics. The industry version can be applied to industrial laser processing, especially suitable for handhold laser welder.



Selection:

Standard Version (Photonics)	Laser Safety Apron (围裙)	Laser Safety Gloves (手套)
Material	<i>Laser Defender</i> [®] Laser safety fabric + dust-free & anti-static & flame retardant outer lining	
Color	Blue	
Weight	1.8kg	
Parameter	PEL=258.09W/cm ² , Wavelength=1070nm, Beam diameter ϕ =1mm, T=100s PEL=72.33W/cm ² , Wavelength=1070nm, Beam diameter ϕ =3mm, T=100s PEL=41.08W/cm ² , Wavelength=1070nm, Beam diameter ϕ =5mm, T=100s	
Upgraded Version (Industry)	Laser Safety+ Apron (围裙)	Laser Safety+ Gloves (护手盾)
Material	<i>Laser Defender</i> [®] Pro Laser safety fabric	
Color	Black	
Weight	6kg	
Parameter	PEL=543.348W/cm ² , Wavelength=1070nm, Beam Radius r=2.509mm, T=100s	
Specifications		
Laser Safety Standard	GB 7247.1/4/13、IEC 60825-1/13、CE/EN 60825-1/4	
Features	Low Reflection, Ageing Resistance, Corrosion Resistance, Flame Retardant & Temperature Resistance, Abrasion Resistance, Dirt Resistance	
Warning	Clothing are damaged with an appearance of white smog, please do NOT continue to use.	
Compatibility	All wavelengths and all lasers	
Application	Class 4 laser, labs, laser devices, laser processing workplace	

Laser Safety Window- Laser Safety World[®]

Laser Safety World[®] windows are manufactured with material of PMMA, compliant with European laser safety standards EN207, and are provided with high level of protection from laser radiation. High optical density(OD) and visible light transmittance(VLT), the windows have no optical distortion and are not easy to scratch. It measures 1280x1000x5mm of one piece of laser safety window, and custom-cutting, punching, chamfering, marking and anti-static are available. *Laser Safety World[®]* windows are widely applied to many areas: laser manufacture, scientific research, laser alignment system, medical and cosmetic facilities.

Standards and Test:

Laser Safety World[®] windows are tested based on standards EN207&EN167, and are compliant with CMA and ilac-MRA, accreditation system which have been integrated to international mutual recognition. It means the Laser Safety World[®] windows are also compliant with CE standards, and meet the threshold of European market.





Selections: please read the following table.



OD (optical density) is the amount of light attenuated by the lens of different particular wavelength that is being measured, e.g.OD4 means a light transmittance of 1/10000, and so on. For more details of OD value of each particular wavelength, please refer to the test report.VLT(visible light transmittance) is the amount of visible light(400-700nm) that can pass through the lens of a pair of glasses. More informally, it means the clearness of the lens of glasses, the higher the VLT value, the clearer the glasses.

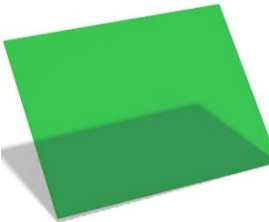

Selections:

P/N	Application	OD	VLT	Photo
WAB-D5T35	UV, Blue laser, Green laser, Wavelength 532nm.	OD7+@190-350nm OD6+@350-380nm OD5+@380-390nm OD4+@390-410nm OD5+@410-460nm OD6+@460-525nm OD5+@525-538nm OD4+@538-542nm	35%	
WAB-D6T30	190-550nm	6+	30%	

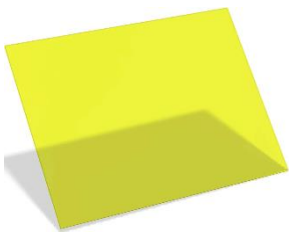
P/N	Application	OD	VLT	Photo
WAC-D5T35	UV, Red laser, Wavelength 630nm, 660nm	OD6+@190-280nm OD5+@280-383nm OD4+@383-400nm OD3+@600-630nm OD4+@630-720nm	35%	
WAD-D5T60	Fiber, IR, wavelength 1064nm, and low light environments	OD7+@190-280nm OD6+@280-335nm OD5+@335-360nm OD6+@360-390nm OD7+@390-440nm OD6+@440-446nm OD5+@446-450nm OD5+@800-809nm OD6+@809-940nm OD7+@940-1100nm	60%	
WAD-D8T55	820-1100nm	8+	55%	
WABD-D5T35	Fiber IR, laser welding/cutting/ cleaning, and wavelength 532nm &1064nm.	OD7+@190-280nm OD6+@280-535nm OD5+@535-540nm OD4+@540-546nm OD3+@800-850nm OD4+@850-900nm OD5+@900-940nm OD6+@940-962nm OD7+@962-1050nm OD6+@1050-1060nm OD5+@1060-1075nm OD4+@1075-1090nm OD3+@1090-1100nm	35%	
WADE-D4T35	Fiber IR, Wavelength 1064nm, laser welding/cutting/ cleaning	OD7+@190-400nm OD6+@400-410nm OD5+@410-425nm OD4+@425-450nm OD4+@900-930nm OD5+@930-960nm OD6+@960-990nm OD7+@990-1165nm OD6+@1165-1185nm OD5+@1185-1200nm OD4+@1200-1220nm OD3+@1225-1240nm	35%	

P/N	Application	OD	VLT	Photo
WADEF-D5T40	Fiber IR, Wavelength 1064nm、 1319nm、 1540nm	OD7+@190-280nm OD6+@280-450nm OD5+@450-460nm OD4+@460-475nm OD3+@475-485nm OD3+@780-820nm OD4+@820-850nm OD5+@850-870nm OD6+@870-950nm OD7+@950-1115nm OD6+@1115-1180nm OD5+@1180-1710nm OD4+@1710-1780nm OD3+@1780-1830nm OD2+@1830-1900nm	40%	
WDEF-D6T30	800-1700nm	6+	30%	
WCO2-D5T75	CO2 laser	OD6+@10600nm	75%	
Laser Safety Film	UV,Fiber IR, Wavelength 1064nm、 1319nm、 1550nm、 2100nm、 2780nm、 2940nm	OD5+@190-360nm OD3+@900-1000nm OD4+@1000-1200nm OD5+@1200-1800nm OD4+@1800-1900nm OD3+@1900-2300nm OD2+@2300-3000nm	50%	

Laser Safety Film, kind of PET film on which are coated with a variety of metal oxides, provides protection from laser radiation of wavelength 780-3000nm by absorbing and reflecting. It is wearable, scratch-resistant, explosion-proof and easy to clean. This protective film can be cutted at any size or shape and attached on any material surface, and can also be used as single, double or multi-layer to provide high level of optical density.

More new products, stay tuned!

Laser Safety Curtains - Laser Defender®

Laser Defender® curtains are provided with high-level protection from laser radiation, and meet the laser safety requirements of class 4 laser. Categorized into 2 series *Laser Defender* and *Laser Defender Pro*, *Laser Defender*® curtains are tested according to laser safety standards GB 7247, IEC 60825 and EN60825. In addition, conformity with CMA and CNAS, accreditation system which have been integrated to international mutual recognition, they are compliant with CE standards, and meet the threshold of European market. Widely applied to laser processing, military industry, semiconductor and medical facilities.

Selections:

Version Photonics	Laser Defender 1520	Laser Defender 1525	Laser Defender 1527
Parameter	PEL > 258.09W/cm ² , Wavelength=1070nm, φ=1mm, T=100s PEL > 72.33W/cm ² , Wavelength=1070nm, φ=3mm, T=100s PEL > 41.08W/cm ² , Wavelength=1070nm, φ=5mm, T=100s		
Thickness	0.6mm		
Weight	0.65kg/m ²		
Version Industry	Laser Defender Pro 1520	Laser Defender Pro 1525	Laser Defender Pro 1527
Parameter	PEL > 543.348W/cm ² , Wavelength=1070nm, r=2.509mm T=100s		
Thickness	1.4mm		
Weight	1.7kg/m ²		
Specifications			
Size	1.5m(W)x2m(H)	1.5m(W)x2.5m(H)	1.5m(W)x2.7m(H)
Material	Composite material with special coating		
Color	Black(other colors custom-designed)		
Laser Safety Standards	GB 7247.1/4/13、IEC 60825-1/13、CE/EN 60825-1/4		
Features	Low Reflection (≈4%) , Aging Resistance, Corrosion Resistance, Flame Retardant & Temp Resistance, Abrasion Resistance, Dirt Resistance、		
Warning	Curtains are damaged with an appearance of white smog, please do NOT continue to use.		
Config/ Std	Eyelets, Laser warning sign, Velcro		
Config/Opt	Track units, Valance, Crossed pulley, outer lining(dust-free & anti-static)		
Compatibility	All wavelengths and all lasers		
Application	Class 4 laser, Laser labs, Laser devices, Laser processing workplace		
Installation	Ceiling- and Floor- mounted, Wall-mounted, using with laser equipment, Straight Run & No Turns, L-Shape, U-Shape, Rectangle Shape		

Laser Defender curtains are suitable for applications of low power lasers, such as optical communication, optical measurement, laser radar, medical&cosmetic, semiconductor& micro-electronics. In contrast, *Laser Defender Pro* curtains are mostly applied to the areas of high-level power lasers, e.g. military industry, industrial laser processing, especially handheld laser processing. With the surface resistance reaching at $10^{10}\Omega$, the curtains can meets the requirements of conventional anti-static. For more demanding in terms of anti-static or dust-free, there's another type of curtains be customized, characterized with surface resistance $10^6\Omega$, anti-friction voltage 100V, especially suitable for the clean room.

There are 2 kinds of installation method for Laser Defender® curtains: ceiling-mounted (sliding open or roller blind) and floor-mounted (freestanding and moveable). We can supplier the track units, roller blind accessories and aluminium frames, depending on customer's demands. The curtains of non-standard size or shape also can be custom-designed to meet the special needs, e.g. a protective cover for machine.

Standard Model Drawing:

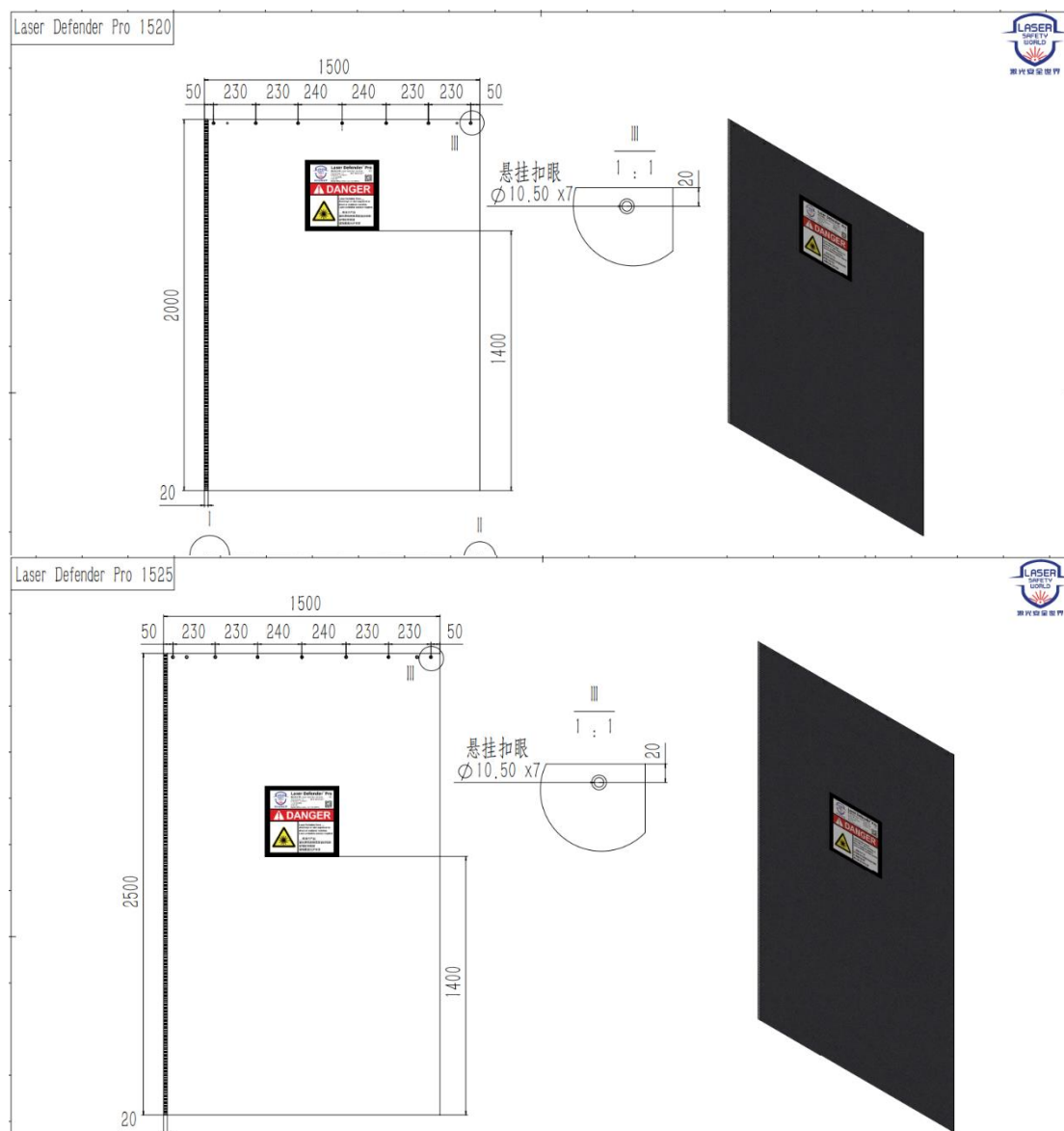

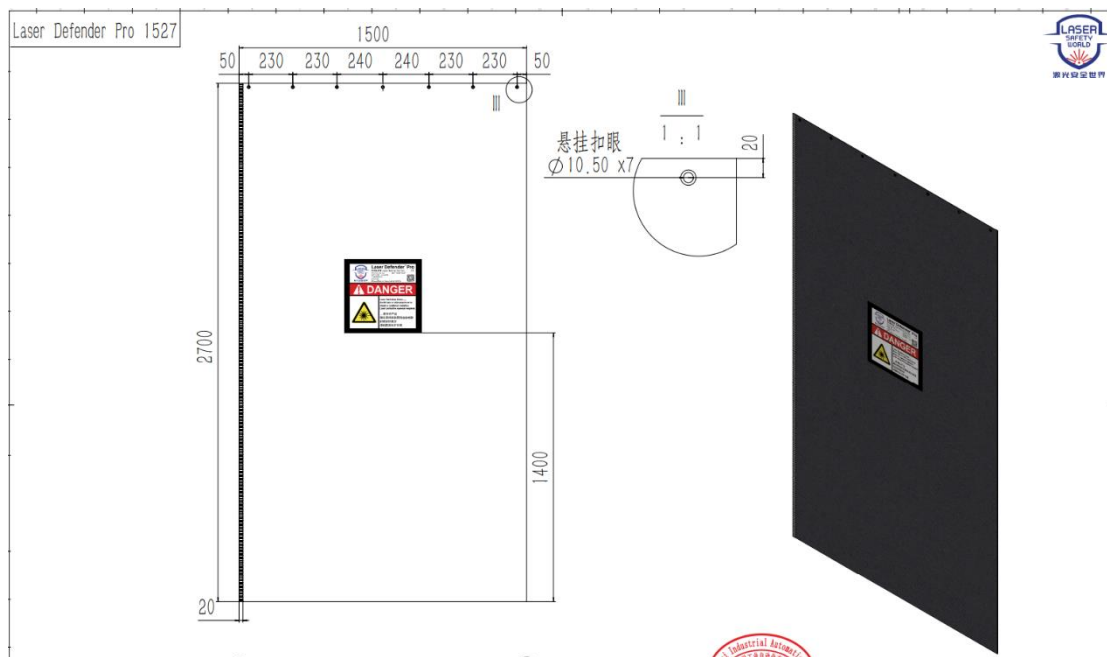

Illustration for Ceiling-mounted:

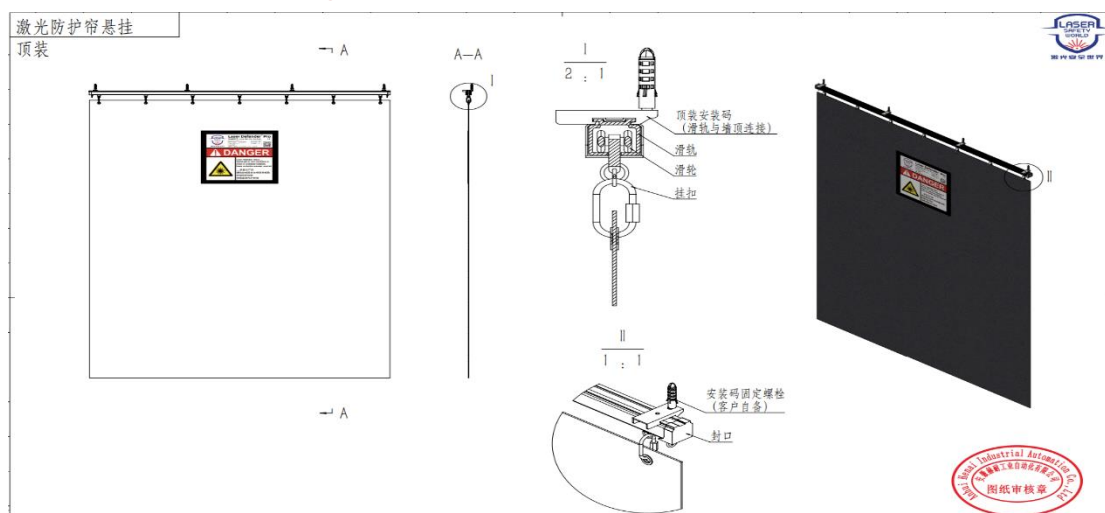

Illustration for Floor-mounted:

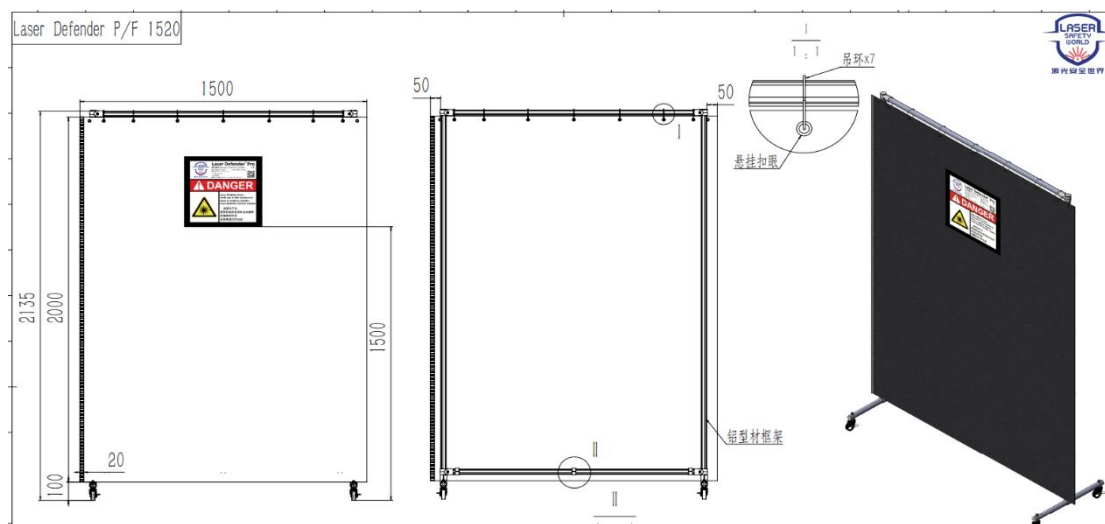
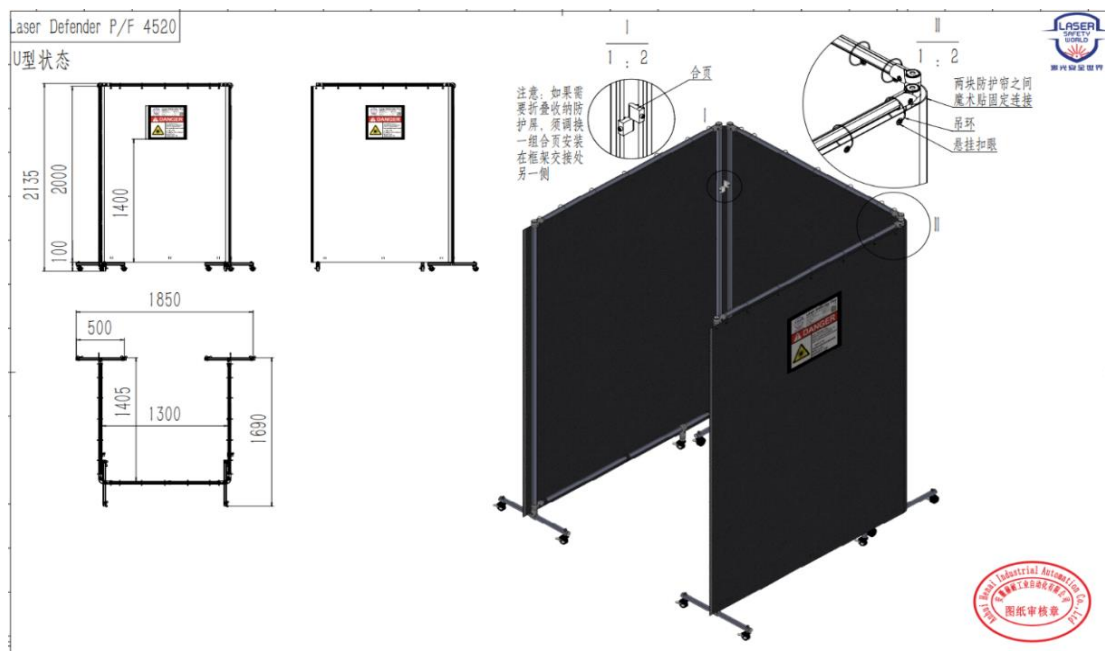

Illustration for Folding:



Case for reference:



Laser Safety Barriers - Laser Knight®

Constructed of the patented panel *Laser Shield 4005™* and aluminum frames, *Laser Knight®* is designed for the protection of kilowatt-level laser, especially for high power laser labs, laser processing workshop and laser device, with its characteristics of high level protection and flexibility. The barriers *Laser Knight*, when they first came out in the year of 2019, successfully get patent for an invention in 2022. They are the first laser protective barriers with independent intellectual property rights in China.

As the rapid growth and wide application of high power laser, HENAI has deeply researched and developed its hit product *Laser Knight* series, and now launch the renewed barriers to meet laser safety demand of high power laser areas. The upgrading barriers are tested by a third party of authority, according to standards GB/T 7247, IEC 60825 and EN60825-1. In addition, conformity with CMA and CNAS, accreditation system which have been integrated to international mutual recognition, *Laser knight* barriers are compliant with CE standards, and meet the threshold of European market. Furthermore in conformity with China national defense recognition of DILAC, *Laser knight* barriers are widely applied to laser processing, military industrial enterprises, the fields of semiconductor and medical facilities.

Laser Shield 4005™ - patent product

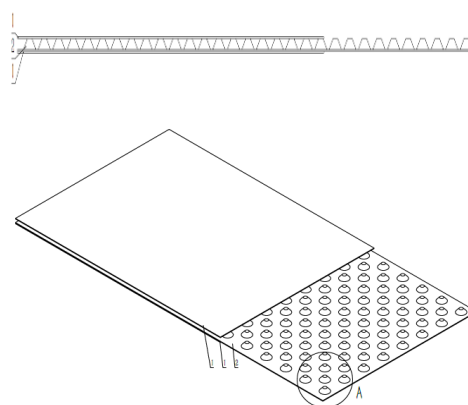

*Two outer panels coated with extinction material withstood high-power laser, provide high level protection from laser radiation, reduce scattering, reflection and diffuse reflection.

*Interlayer panel with frustum structure of staggered layout

Selections:

Barriers I	Laser Knight 0821	Laser Knight 1521	Laser Knight 1527
Standards	GB/T 16601.1-2017 《激光器和激光相关设备激光损伤阈值测试方法》		
Laser Damaged Threshold	1529.3W/cm ² (Wavelength=1064nm,Beam D≈3mm,T=100s) 1126.9W/cm ² (Wavelength=1064nm,Beam D≈5mm,T=100s)		
Barriers II	Laser Knight 0821 II	Laser Knight 1521 II	Laser Knight 1527 II
Standards	GB 7247.1/4/13、IEC 60825-1/4/13、CE/EN 60825-1		
PEL	PEL > 15805.10W/cm ² (Wavelength=1070nm,φ=1mm,T=100s)		
Specifics			
Size	0.795m(W)x2.148m(H)	1.545m(W)x2.148m(H)	1.545m(W)x2.663m(H)
Thickness	4mm, three-tier structure, Patent No.: ZL 2021 1 0930929. 4		
Material	Laser Shield 4005™ Panel(composite material with special coating) + Aluminum frames		
Color	Black/Gray (black only for Barrier II)		
Features	Low reflection、 Aging Resistance, Corrosion Resistance, Flame Retardant & Temperature Resistance, Abrasion Resistance, Dirt Resistance, Anti-static (BLACK)		
Warning	Barriers are damaged with an appearance of white smog, please do NOT continue to use.		
Config / Std	Laser safety warning signs		
Config / Opt	Laser safety window		
Compatibility	All wavelengths and all lasers		
Application	Class 4 laser, Laser labs, Laser devices, Laser processing workplace		
Installation	Floor- mounted, Used with laser device, Straight Run & No Turns, L-Shape, U-Shape, Rectangle Shape		

Drawings of Standard Model:

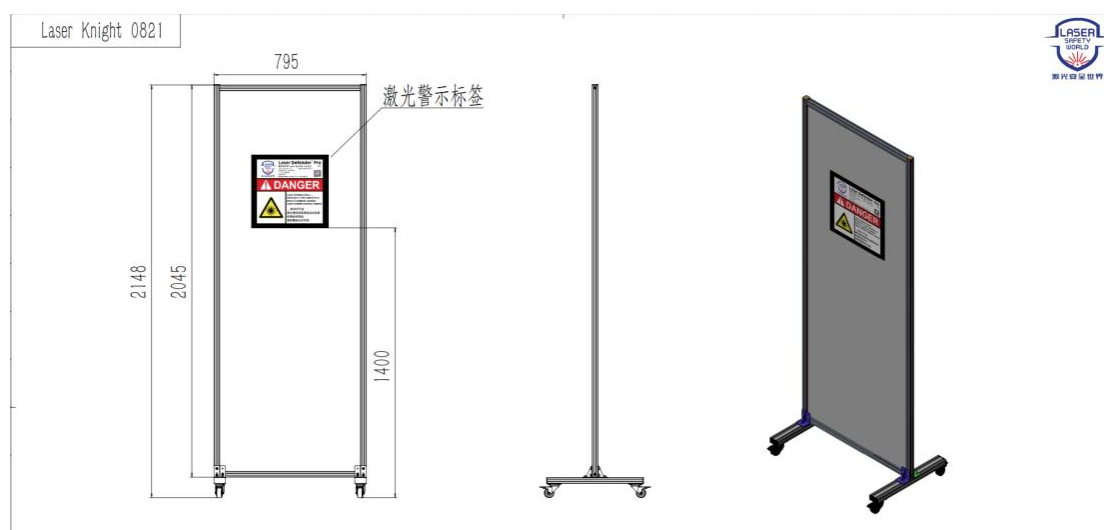

Drawings of Standard Model:

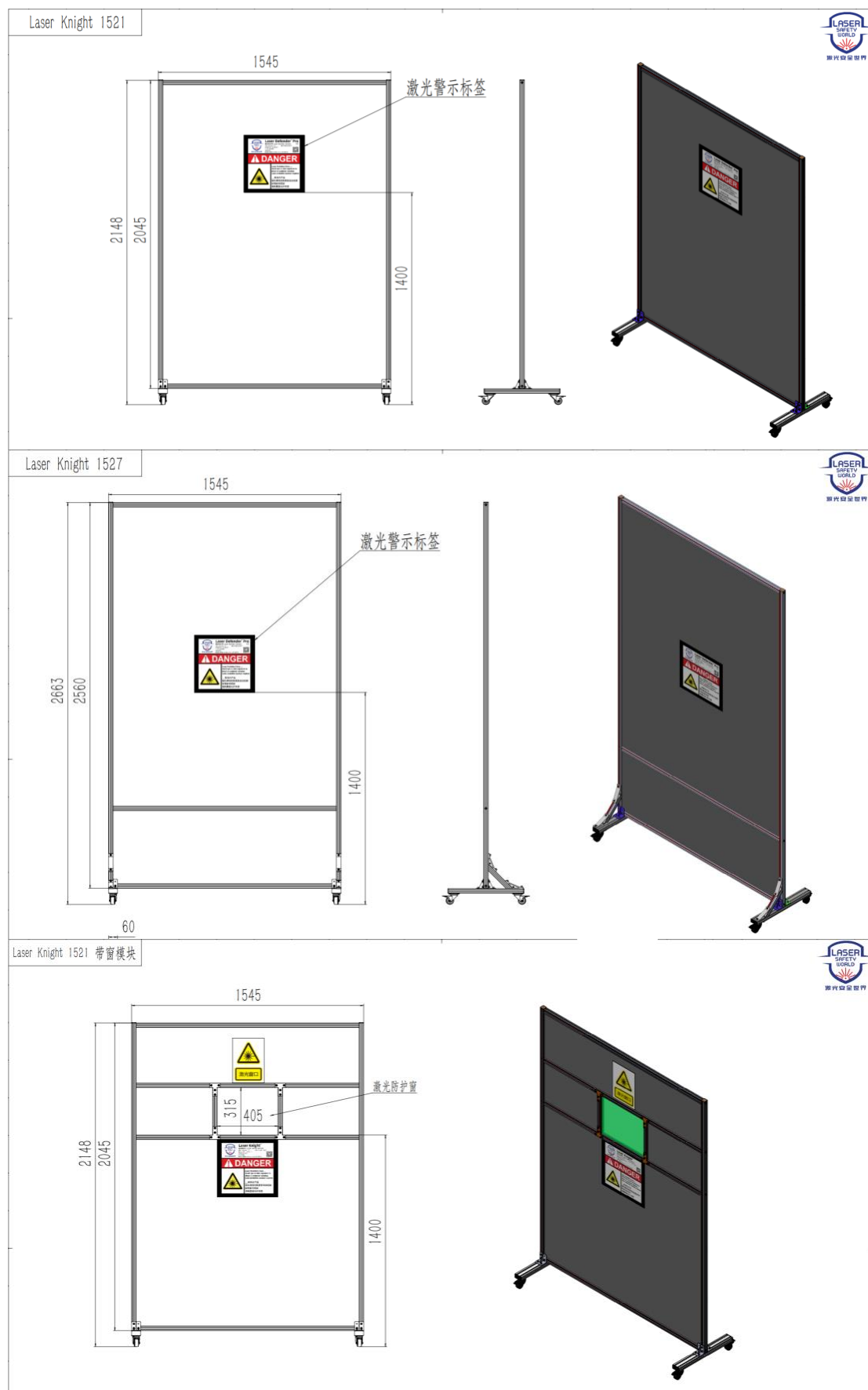
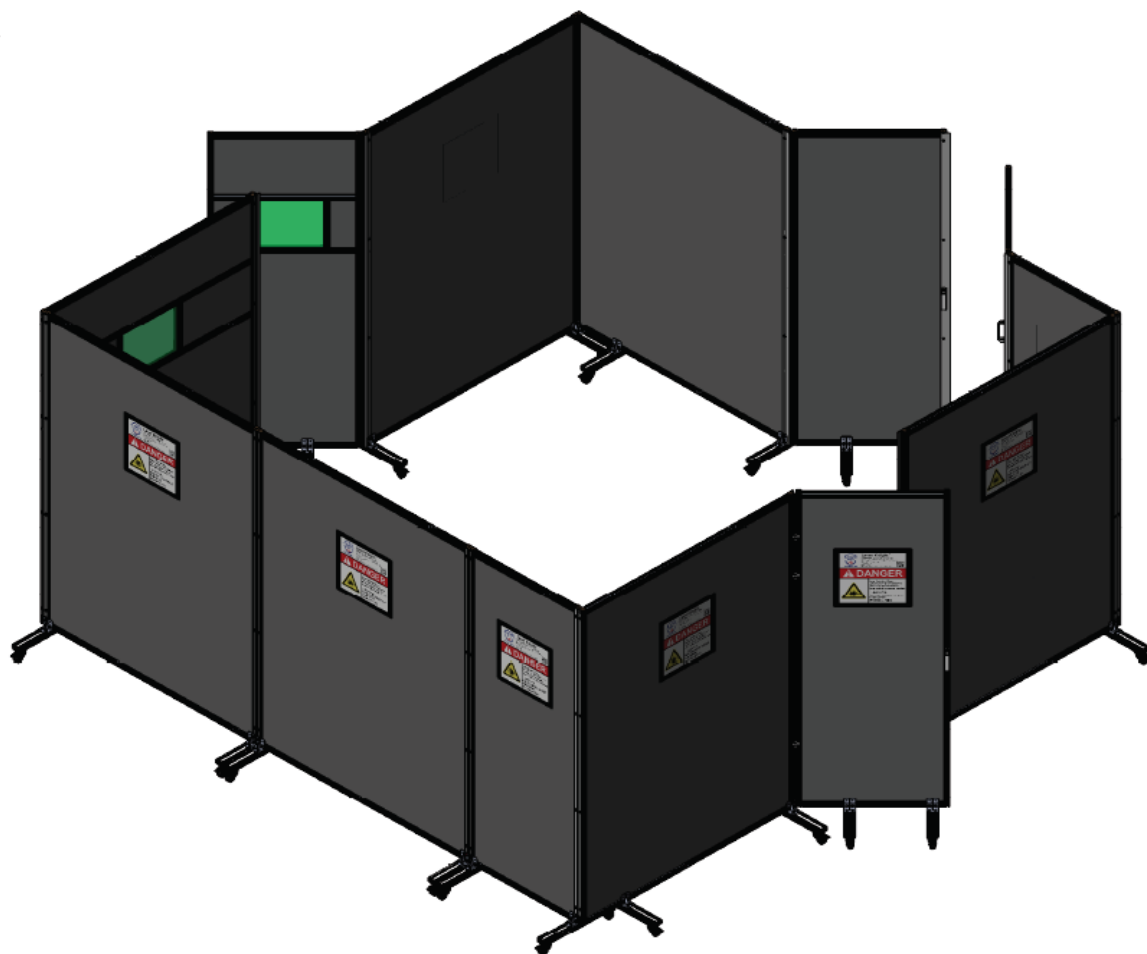

Illustration of Barriers Combination:



Cases for Reference:



Optical Table Laser Guarding System - Laser Hero®

Laser Hero® laser shield are installed on or around an optical table to help block, absorb, and diffuse scattered and direct laser radiation escaped from the optical system. This guarding system must be able to withstand a high power density, in consideration that it is very close to laser source, and in this circumstance even a stray light may have a lot of energy(when the beam power reaches kilowatt-level, the power of the stray light may be tens of watt or even hundreds of watt, and even though a metal plate could be damaged).

Laser Hero® system is fabricated of laser blocking walled panels *Laser Shield 2020*™, which are tested according to laser safety standards GB 7247, IEC 60825 and EN60825. In addition, conformity with CMA and CNAS, accreditation system which have been integrated to international mutual recognition, *Laser Hero*® system are compliant with CE standards, and meet the threshold of European market. This *Laser Shield 2020*™ is constructed of black matte material with surface uniformly concave and convex to minimize the stray light. It is rated at: PEL > 45652.174W/cm² (φ1mm) , ideal for application of high-power laser at short range.

Patent Certificate:

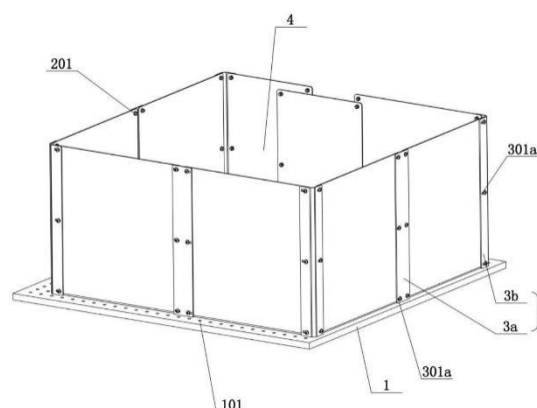

Selections:

Standard Model	Dimensions	Photo
Laser Hero® 3020	200mm (W) x305mm (H)	
Laser Hero® 3030	300mm (W) x305mm (H)	
Laser Hero® 3040	400mm (W) x305mm (H)	
Laser Hero® 3060	600mm (W) x305mm (H)	
Laser Hero® CF	Straight Connector	
Laser Hero® CC	90-degree Corner Connector	

Drawings of Standard Model:

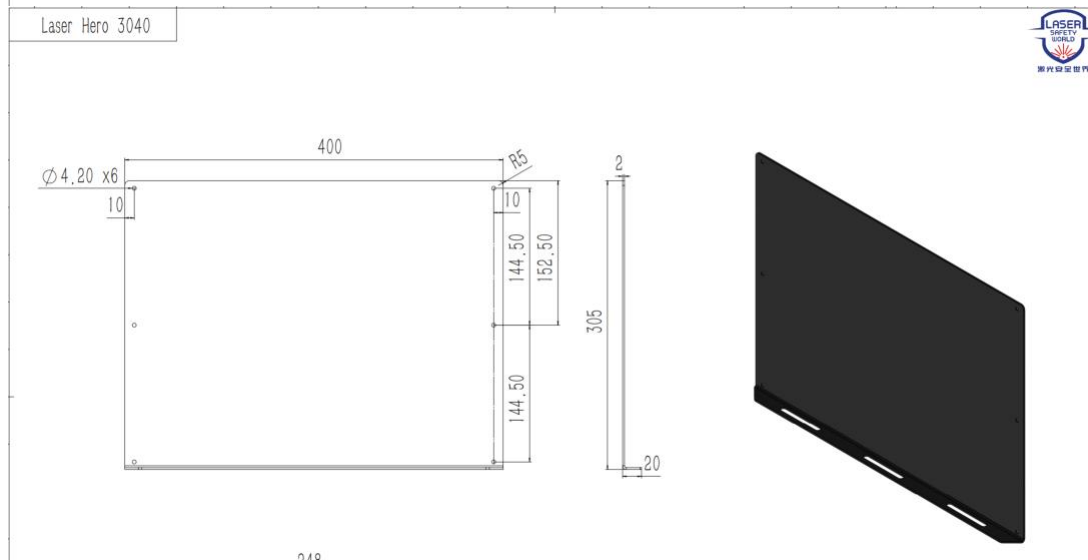
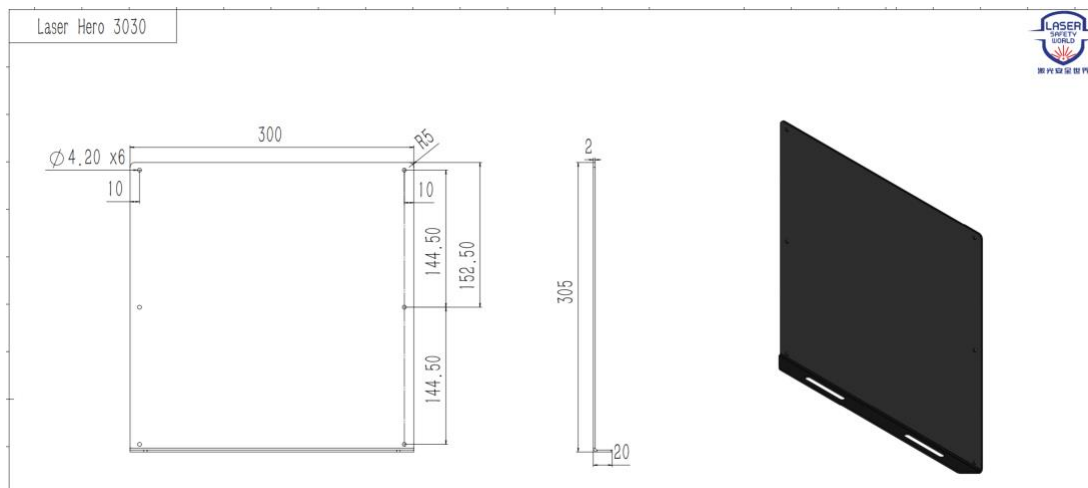
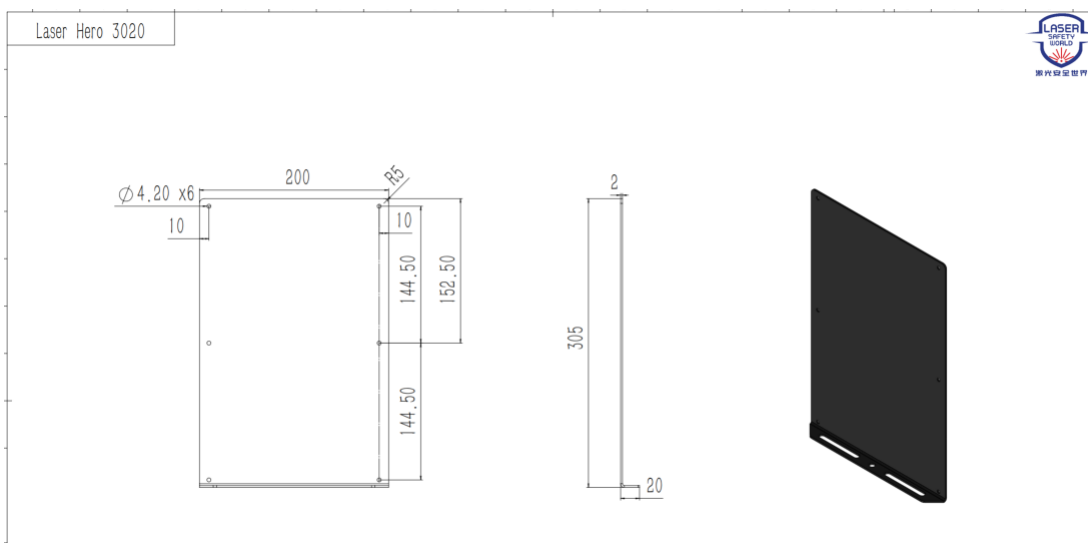

248

Drawings of Standard Model:

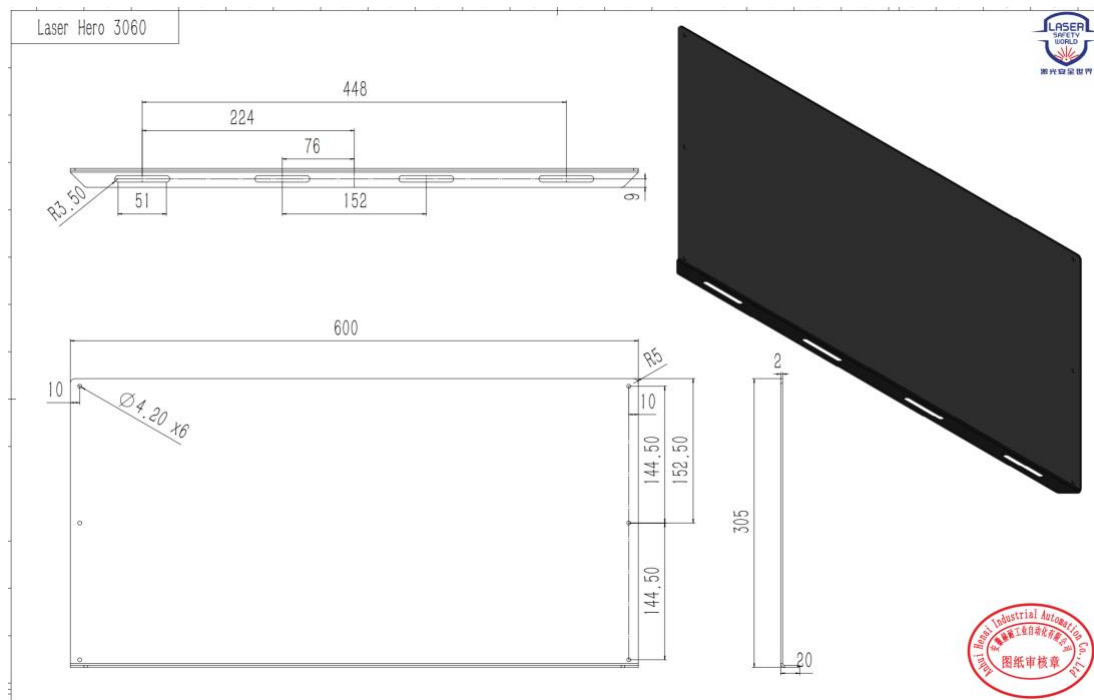

Installation Instruction:

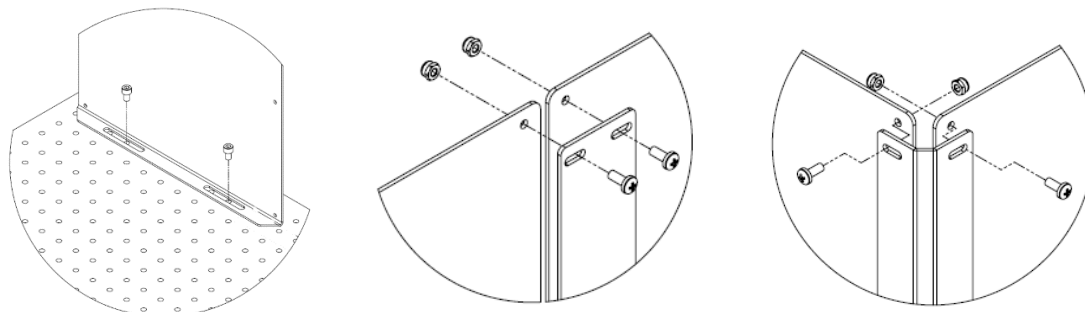

Laser Safety Enclosure - Laser Cage[®]

This patent enclosure *Laser Cage*[®] is applied to provide protection for small laser device, such as optical table in a lab, and desktop laser machine. This *Laser Cage*[®] enclosure must be able to withstand a high power density, in consideration that it is very close to laser source, and in this circumstance even a stray light may have a lot of energy(when the beam power reaches kilowatt-level, the power of the stray light may be tens of watt or even hundreds of watt, and even though a metal plate could be damaged).

Laser Cage[®] enclosure is fabricated of laser blocking walled panels *Laser Shield 2020*[™], which are tested according to laser safety standards GB 7247, IEC 60825 and EN60825. In addition, conformity with CMA and CNAS, accreditation system which have been integrated to international mutual recognition, this *Laser Cage*[®] enclosure is compliant with CE standards, and meet the threshold of European market. This *Laser Shield 2020*[™] is constructed of black matte material with surface uniformly concave and convex to minimize the stray light. It is rated at: PEL > 45652.174W/cm² (φ1mm), ideal for application of high-power laser at short range.

Patent Certificate:

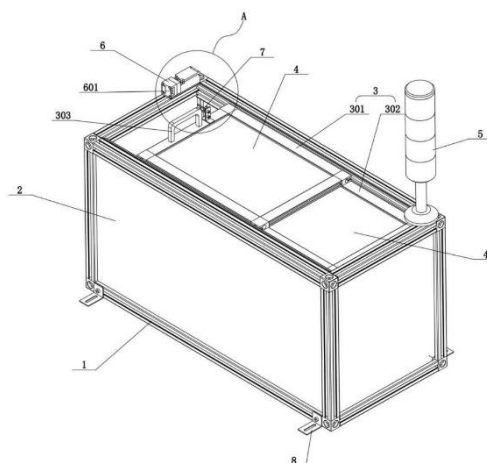

Design Drawings for reference:

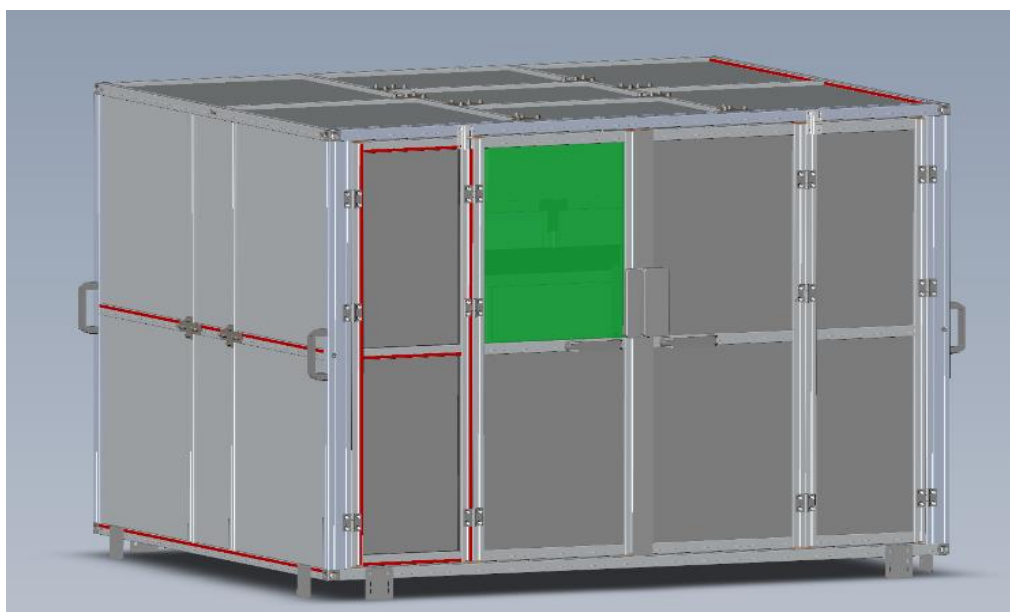

Design Drawings for reference :

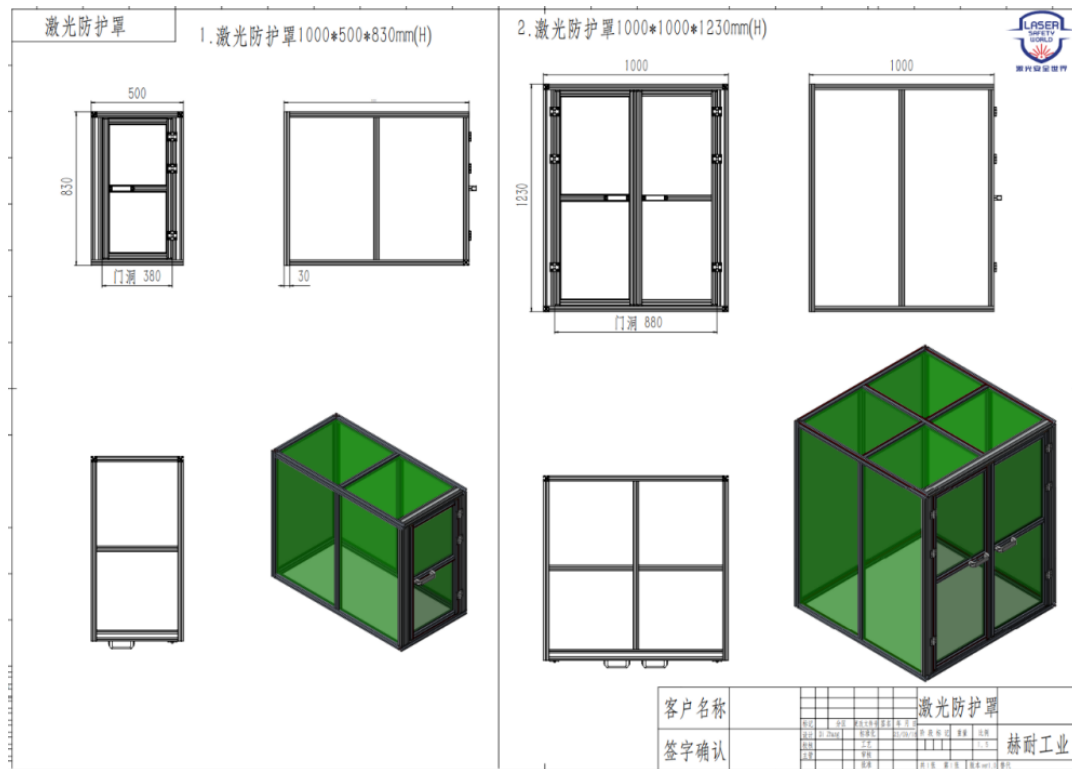

The custom-manufacture Laser Cage® enclosure comprises of integrated lighting, laser safety windows, interlock system, laser warning signs and dust&fume extraction system. HENAI has experience in showing you different solutions regarding the design of entries of fibers, cables, water pipes and gas lines and so on.

Successful Cases:

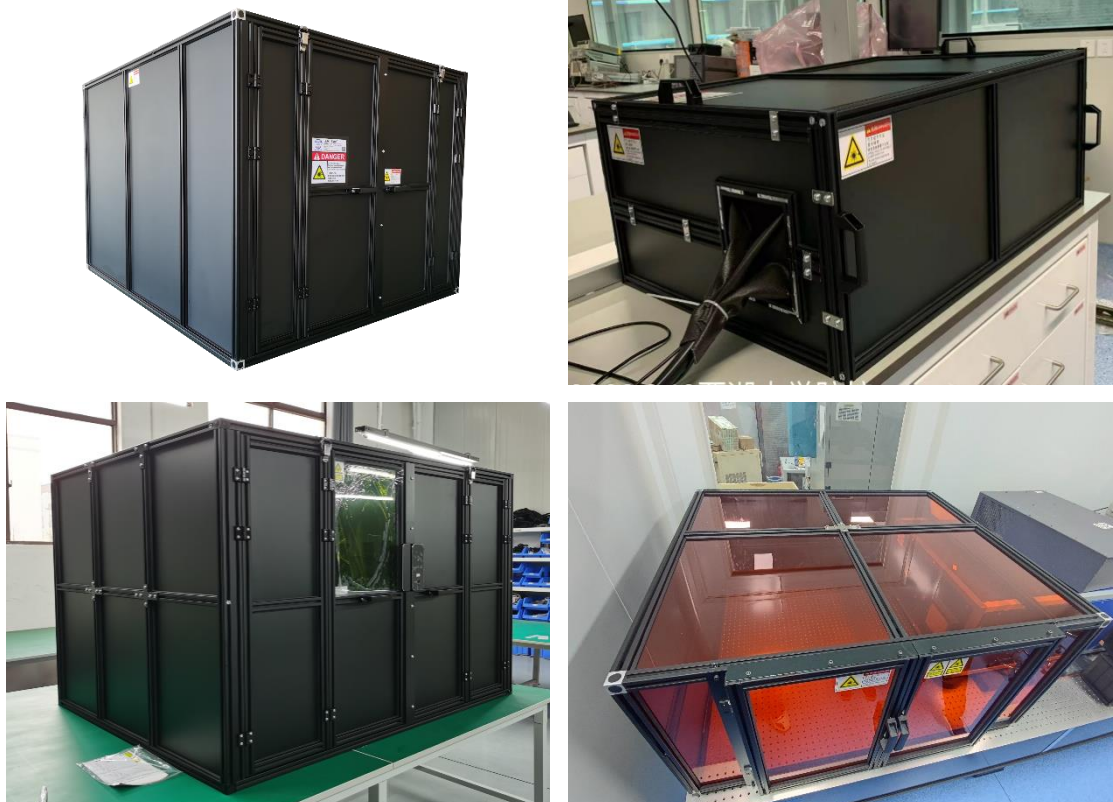

Laser Safety Cabin - Laser Castle®

The patented *Laser Castle*® cabin is applied to provide a enclosed protection for large laser device and large working place, which usually come to the complex paths of light, operation procedures and site conditions, e.g. laser lab, industrial laser processing and so on.

Laser Castle® cabin comprises of laser safety window, door, interlock system, laser warning signs and video monitoring system and so on. It is a complete laser safety solutions, and is compliant with national standards GB7247.1 and European standards EN60825-1. A fume&dust extraction system could furthermore be considered to be equipped, to keep the laser light path clean and operator health.

During the passed 10 years, more than tens of laser safety cabins applied to scientific universities, new energy vehicle and aerospace have been built. HENAI can provide a full range of service such as evaluation, design, fabrication, assembly and test, in addition the test report also can be supplied, which is compliant with CMA, CNAS,CE, TUV certificate.

Patent Certificate :



Design Drawings for reference :

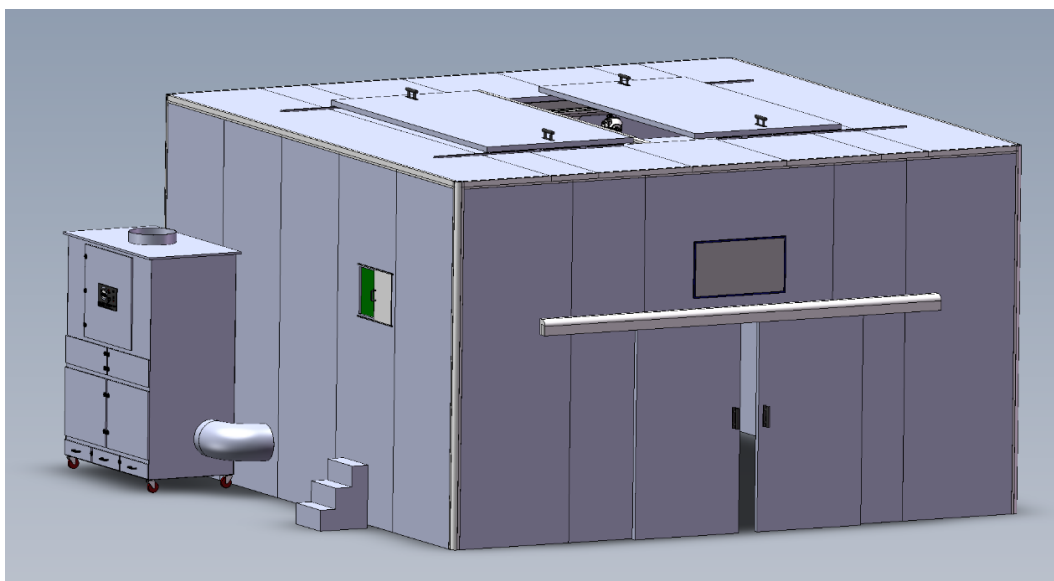

Design Drawings for reference :

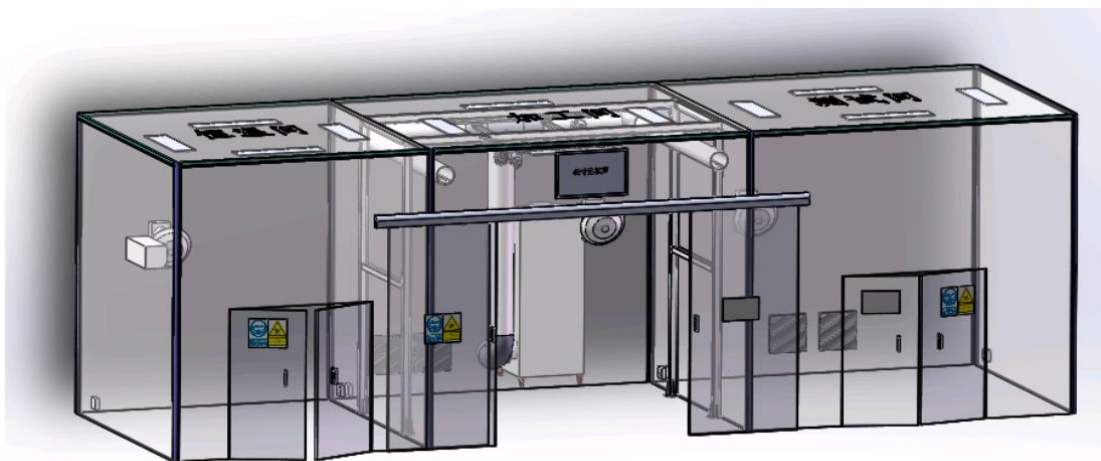

Successful Cases :



Laser Safety Interlock Controller

This unit can control laser interlocks, door locks, illuminated warning signs and other equipment. It is compliant with standard EN954-1 & EN ISO 13849-1 PLe (Cat 3 safety system, performance level ‘e’), EN61508 (SIL 4), EN61010, EN60947-1, and widely applied to laser labs, hospital operating rooms, laser manufacturing and testing areas. For more details about laser interlock, please feel free to contact us.

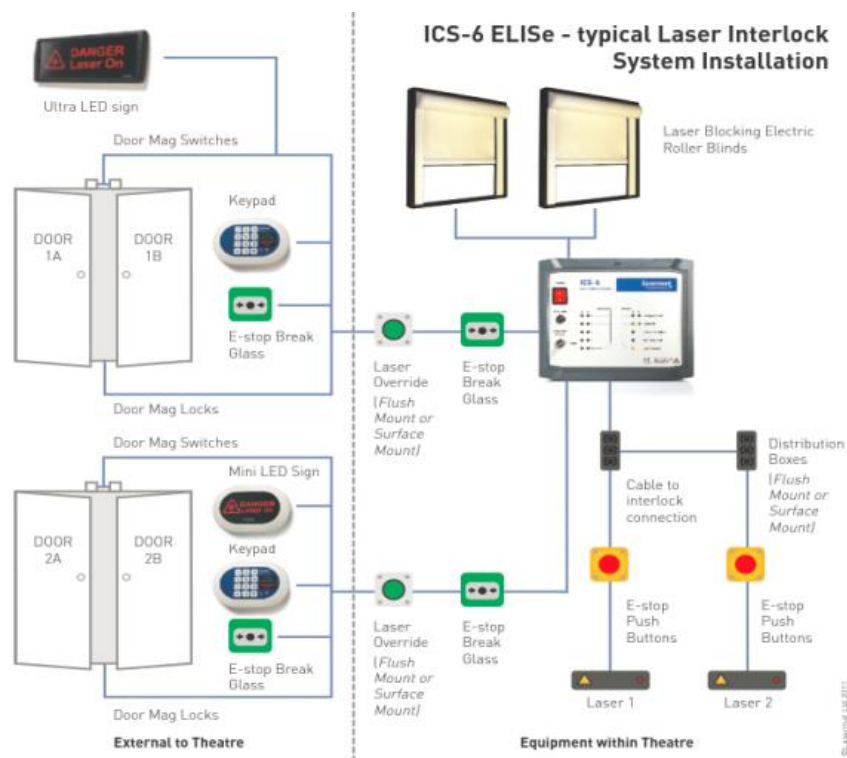

Active Laser Guarding System

High beam power (>1kW) in small beam diameters will cut through steel and even firebricks in a relatively short period of time. For very high beam powers (>5kW), even large beam diameters have the potential to break through concrete. . In these circumstances passive guards must be far enough removed from the laser aperture to ensure they can withstand the beams power density. This is not always practical.

Active Laser Guarding System is based on multi-layer laser safety curtain and electronic induction device. If a laser beam is directed at protective curtains, the electronic induction device will detect and turn the laser off within 120ms through the interlock controller.

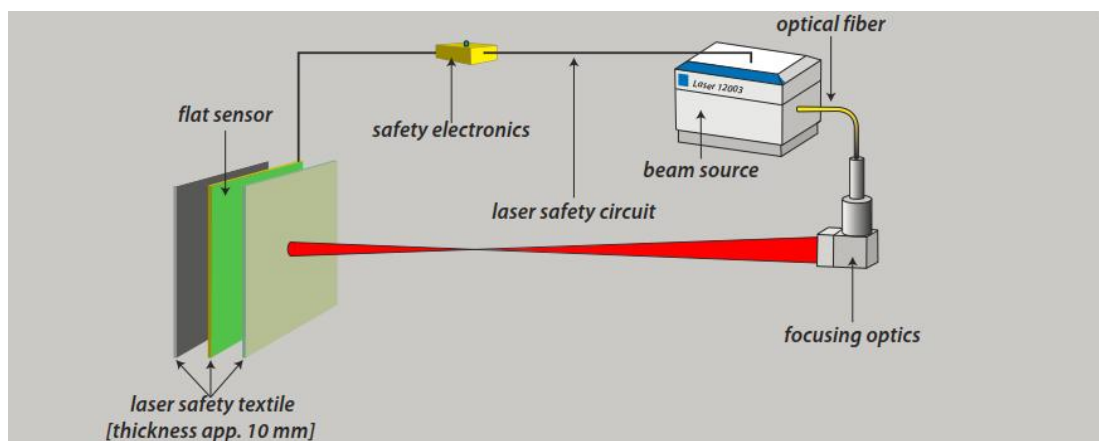

Disclaimers

1. When buying laser safety products, please read carefully the products specifications, because of the specific laser-rated safety parameters for each product. We are not responsible for any accident caused by incorrect selection and use of products out of range of laser-rated safety.
2. Laser operators should consider working environments, viewing conditions and beam delivery systems when making assessments and determining the correct laser safety products. Please consult with your laser safety officer or the third-party organization for correct equipment and use.
3. Watt-level lasers can burn skin and go blind. Kilowatt-level lasers can penetrate thick steel plate. 10,000-watte-level lasers can penetrate concrete walls. All our products are designed and manufactured to prevent an occasional short time (in second) laser reflection and scattering. In any case, laser beam is interdicted to hit directly on person or laser safety products. We are not responsible for any accident due to incomprehension of laser hazard and nonobservance of laser safety standards and wrongful operation.
4. We are not be liable in any case for any damage, including the loss of profit.